

- THREAD NOTES:
- 6 THREADS PER INCH
  - 1 TURN OF THREAD
  - THREAD START 90° TO P/L
  - "M" STYLE THREAD PROFILE

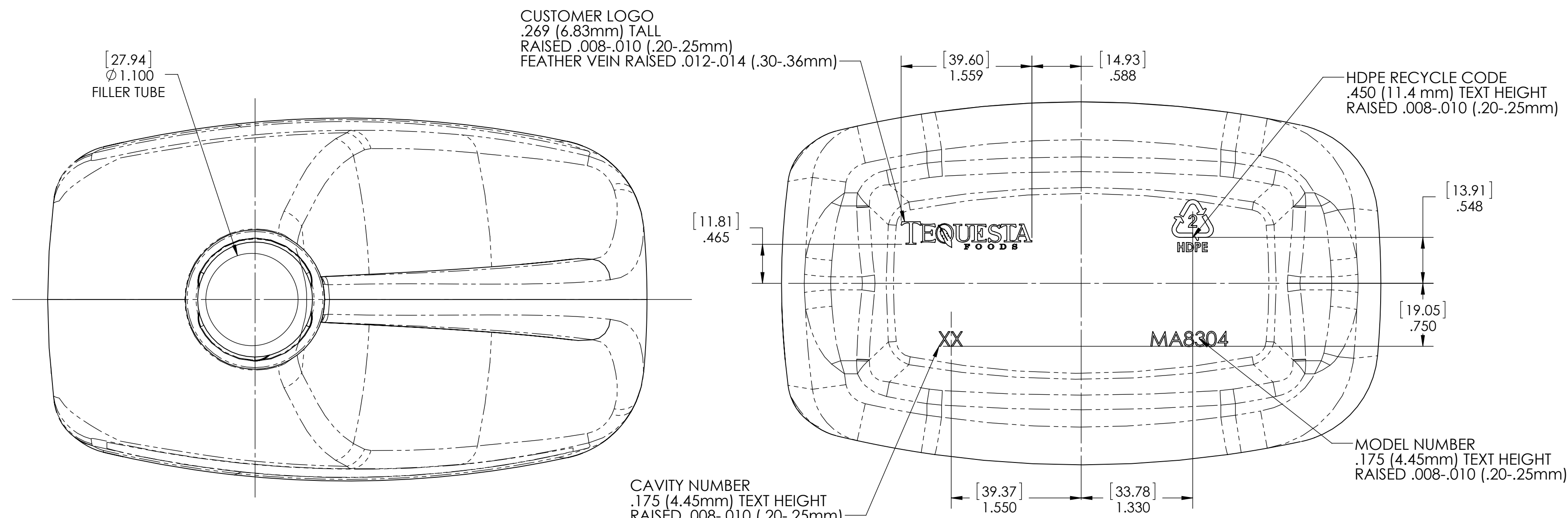

- Notes:
- Tolerances Unless Specified:  
Vertical -- ±.080" (2.03 mm)  
Horizontal -- ±.090" (2.29 mm)  
Volumetric -- ±1.5 oz
  - Bottles to be Checked Aged with 20°C water
  - Estimated Bulge -- 1.6 oz

<b>PROPRIETARY AND CONFIDENTIAL</b> <small>THE INFORMATION CONTAINED IN THIS DRAWING IS THE SOLE PROPERTY OF MID-AMERICA MACHINING, INC. ANY REPRODUCTION IN PART OR AS A WHOLE WITHOUT THE WRITTEN PERMISSION OF MID-AMERICA MACHINING, INC. IS PROHIBITED.</small>	Drawn By: KDG	Date: 25MAR13	Container Data:	
	Checked: MJS	Date: 25MAR13	Weight	160 grams
	Customer: Multi Container		Fill Level Capacity	128 oz
	Job #: 18398		Overflow Capacity	130.6 oz
Reference Materials:		Material	HDPE	
	MA-P-2012-REV-B	Avg. Wall Thickness		

 Brooklyn, MI		Description: Product Drawing 128 oz No Glug Oil
Size: D	Drawing Number: MA8304-2	REV
Scale: 1:1		SHEET 1 OF 2