

NECK DETAIL 70mm MAC
2X SCALE

THREAD NOTES :
 1. 8 THREADS PER INCH
 2. THREAD START 90° TO P/L
 3. 1-1/2 (540°) TURNS OF THREAD
 4. "M" STYLE THREAD
 5. MAC #70MM-C

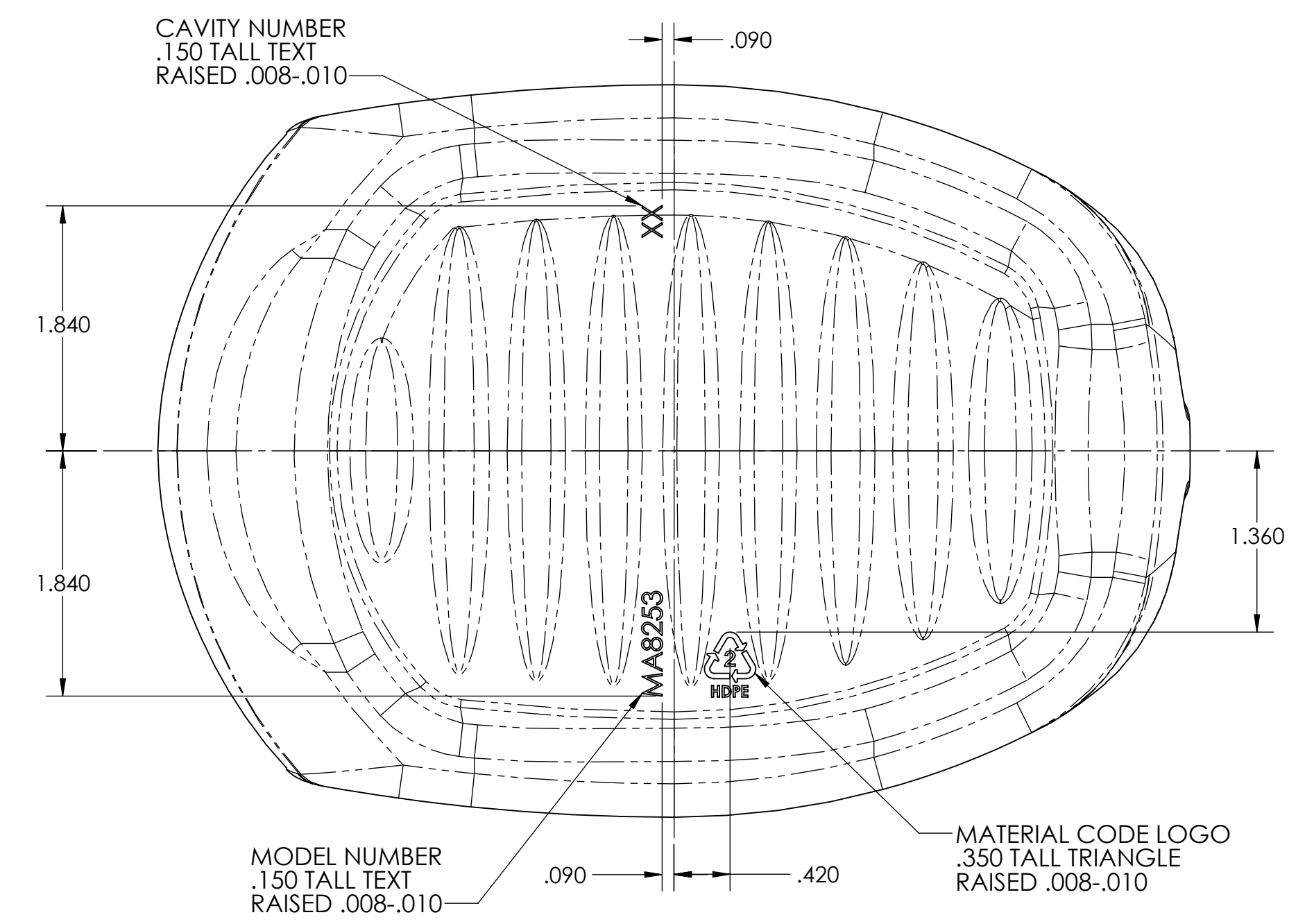

Notes:
 1) Tolerances Unless Specified:
 Vertical -- $\pm .060$
 Horizontal -- $\pm .060$
 Volumetric -- ± 1.30 oz
 2) Bottles to be Checked Aged with 20°C water
 3) Estimated Bulge -- 1.6 oz

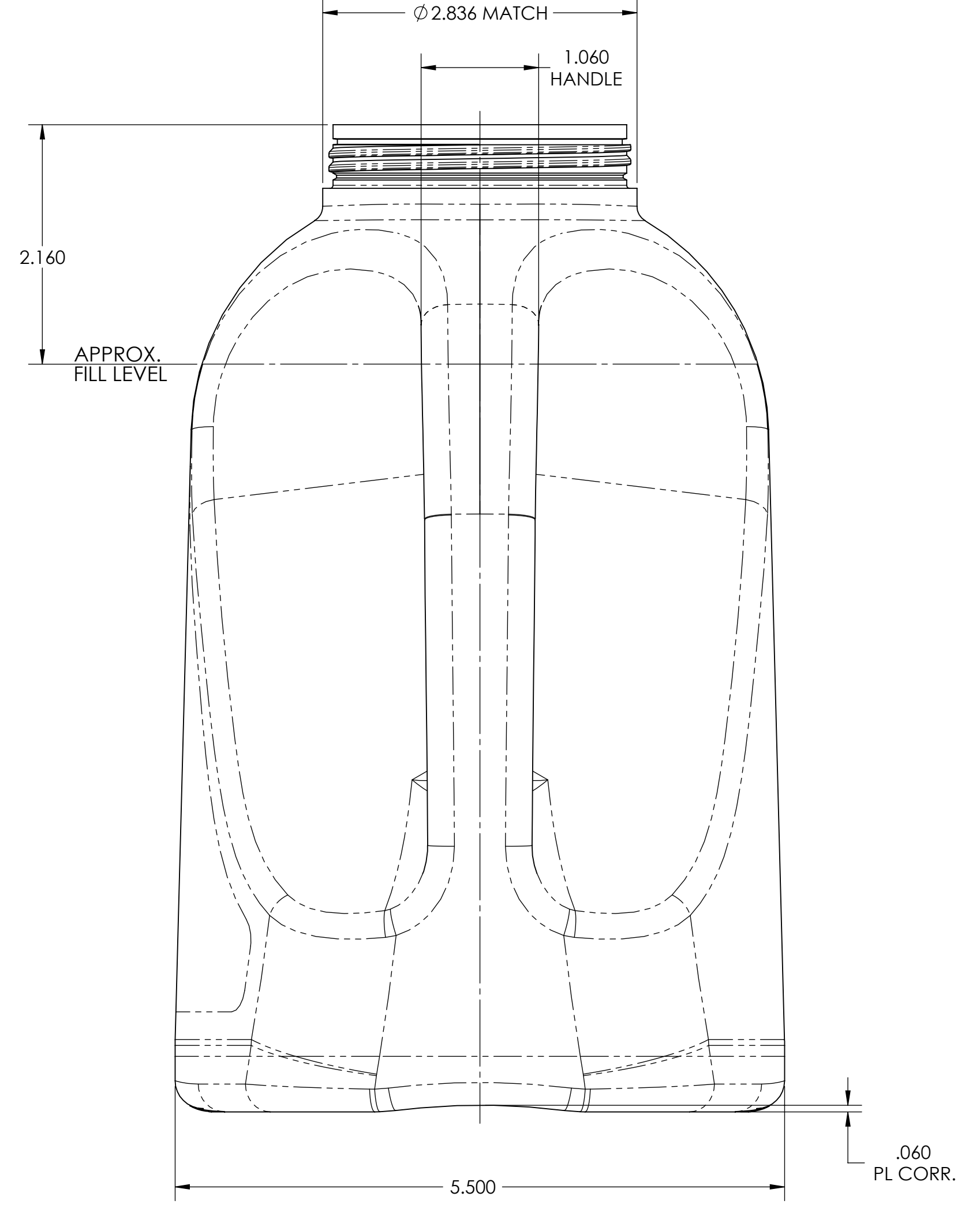
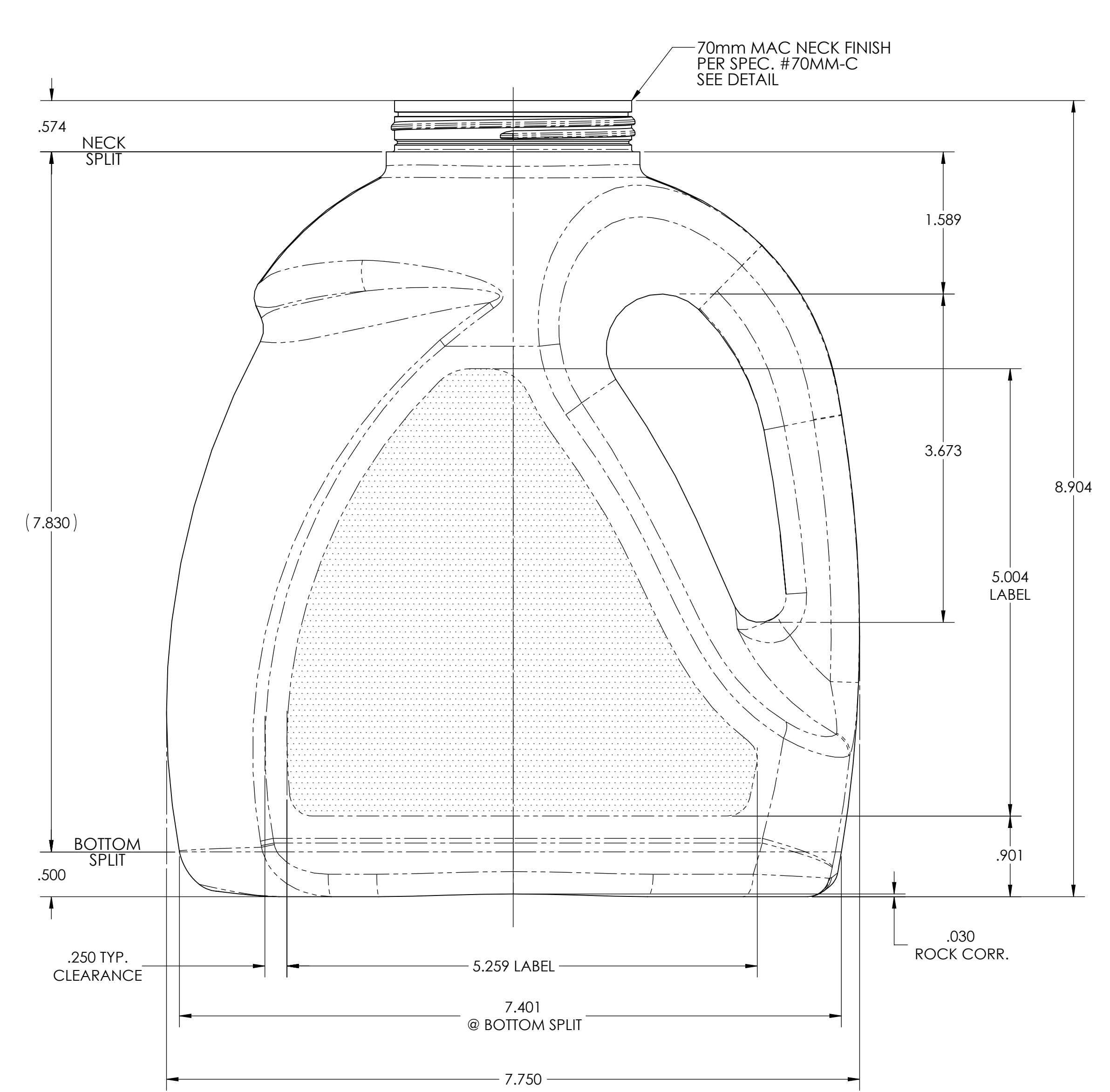

| | | | | |
|--|--|---|--|--|
| PROPRIETARY AND CONFIDENTIAL <small>THE INFORMATION CONTAINED IN THIS DRAWING IS THE SOLE PROPERTY OF MID-AMERICA MACHINING, INC. ANY REPRODUCTION IN PART OR AS A WHOLE WITHOUT THE WRITTEN PERMISSION OF MID-AMERICA MACHINING, INC. IS PROHIBITED.</small> | Drawn By: MJS Checked: KDG Customer: Multi Cont. | Date: 10/19/2011 Date: 10/19/2011 Job#: 15181 | Container Data: Weight: 140 grams Fill Level Capacity: 100.0 oz Overflow Capacity: 112.8 oz | Description: Product Drawing 100 oz Fabric Softener |
| | Reference Materials: MA-P-1519-B | Material: HDPE Avg. Wall Thickness: | Size: D Scale: 1:1 | Drawing Number: MA8253-2 REV: 1 OF 1 |